

KABELSCHLEPP

TKK series

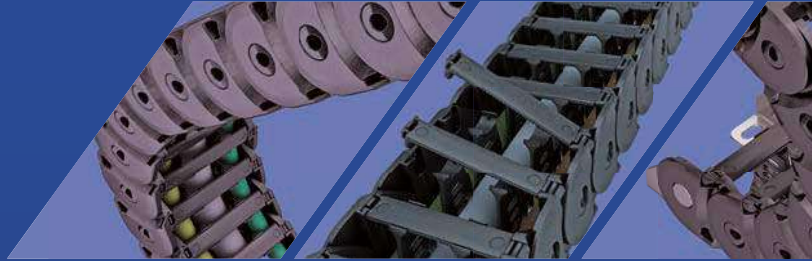

CABLE CARRIER MADE OF PLASTIC
VERY SHORT END CONNECTORS
DIRT RESISTANT

TKK series

Dirt-repellent cable carriers
made of plastic

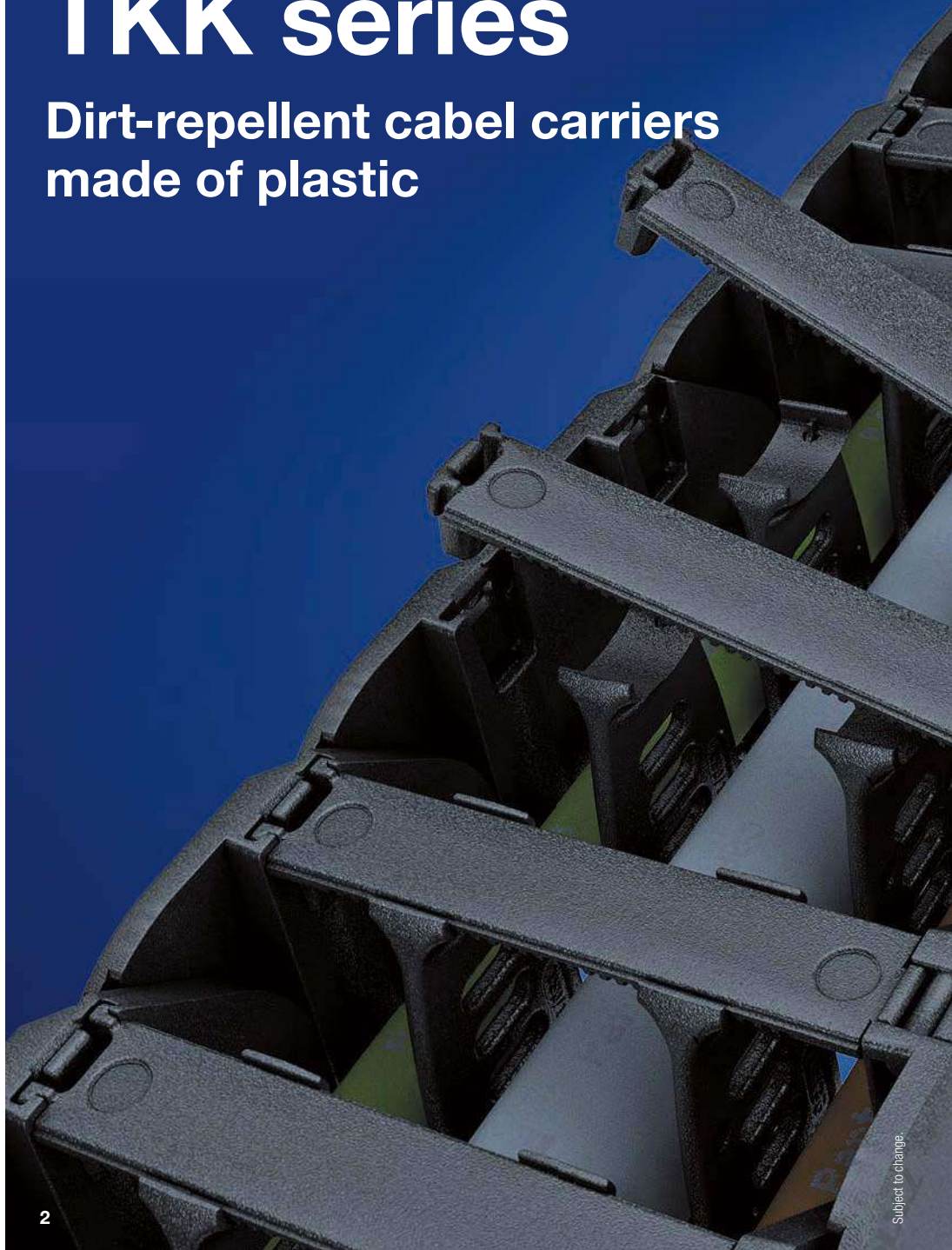



Inner height
39 mm



Inner widths
74 mm



Pitch
39 mm



Additional load
up to 10 kg/m



Travel length unsupported
up to 5 m



Travel length gliding
up to 80 m



Travel speed
up to 3 m/s



Travel acceleration
up to 9 m/s²

All technical data and features depend on application and type.
Let us know your requirements – we are here to help!

Fon: +49 2762 4003-0 or

E-mail: technik@kabelschlepp.de



Features

- High torsional rigidity
- Optimized dividers for cable protection: rounded inner and outer profile
- Extensive unsupported lengths
- New dirt-repellent construction of chain links as well as chip protection
- Smooth surface for easy operation due
 - Designs with closed frame and with inward opening crossbars
 - Very short end connectors
 - Fixable dividers
 - Optimized stroke system



Optimized dividers for cable protection



New construction of chain links. Repellent against dust and chips in the link design, dirt-repellent

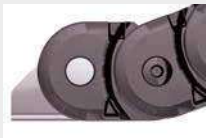

Very short end connectors

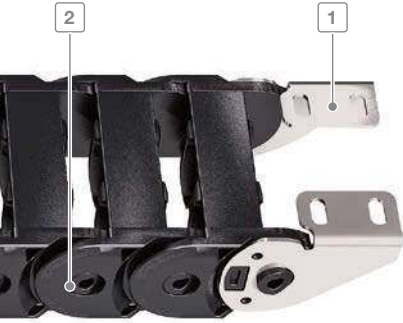

- 1 Very short end connectors made of steel
- 2 Chain links made of plastic
- 3 Extensive unsupported length
- 4 Repellent against dust and chips in the link design
- 5 Smooth surface for easy operation due
- 6 For inward opening (design 040)
- 7 Dividers and height separations for cable separation



Example of inner distribution

Selection criteria for TKK

- Where an extensive unsupported length is required
- Where rigidity is required
- If the installation area is very restricted
- For dirty environmental conditions or dirty environmental conditions (dirt resistant)
- If an optional divider fixing should be available (e.g. for cable carrier laying on its side)
- If a gliding arrangement should be optionally available

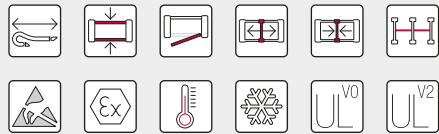

Inner heights



Inner widths



Key for abbreviations on page 22

Assembly instructions on kabelschlepp.de/assembly

Type	h_i [mm]	B_i [mm]	t [mm]	Page
TKK39	39	74	39	8

TKK39



Pitch
39 mm

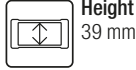

Height
39 mm



Width
74 mm



Bending radius
46 – 95 mm

kabelschlepp.de/
tkk

Configure your cable carrier:
online-engineer.de

Stay variants

Design 020

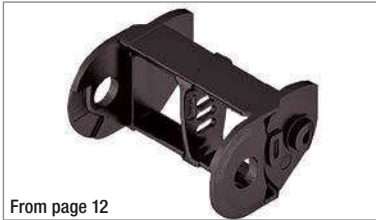

From page 12

Closed frame

- Weight-optimized, closed plastic frame with particularly high torsional rigidity.

Opening options

outside/inside: Closed.

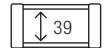

Design 040



From page 14

Frame with inside opening crossbars

- Weight-optimized plastic frame with particularly high torsional rigidity.
- Swivable crossbars on one side in any position.

Opening options

inside: Swivable.

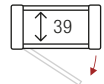

Technical support:
technik@kabelschlepp.de





TKK

Inner heights



Inner widths



Key for abbreviations
on page 20

Assembly instructions on
kabelschlepp.de/assembly

Order key
on page 19



Unsupported arrangement

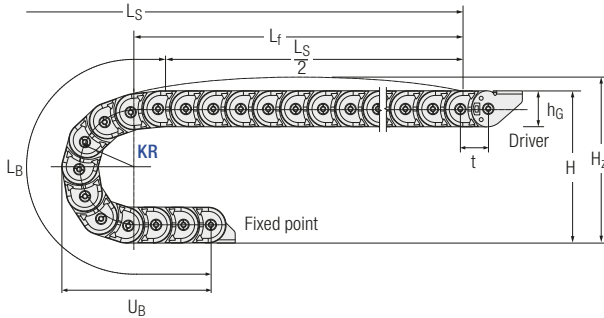

Unsupported length L_f

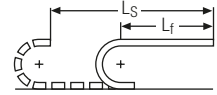

A sagging of the cable carrier is technically permitted for extended travel lengths, depending on the specific application.

Dynamics of unsupported arrangement

v_{\max} [m/s]	a_{\max} [m/s ²]	t [mm]
3	9	39

Installation dimensions unsupported

KR [mm]	H [mm]	H _z [mm]	L _B [mm]	U _B [mm]
46	142	172	222	149
58	166	196	260	161
70	190	220	298	173
95	240	270	376	198

Load diagram

for unsupported length depending on additional load

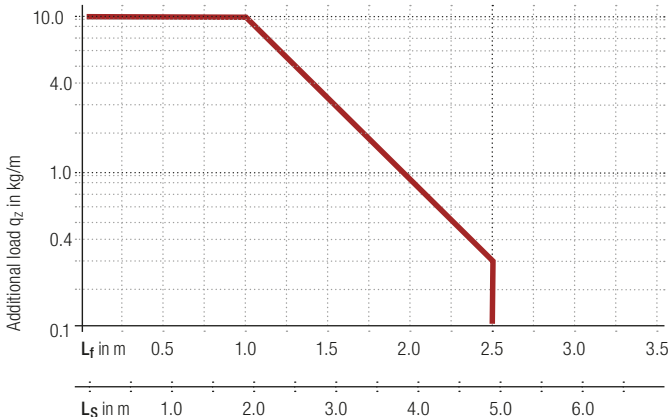

Calculating the cable carrier length

Cable carrier length L_k

$$L_k \approx \frac{L_S}{2} + L_B$$

Cable carrier length L_k rounded to pitch t

Unsupported length L_f

$$L_f = \frac{L_S}{2} + t$$



Fixed point offset L_f :

For off-center fixed point connections please contact us.



Intrinsic cable carrier weight $q_k = 1.56 \text{ kg/m}$
For other inner widths the maximum additional load changes.

Gliding arrangement

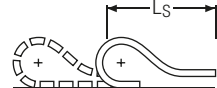
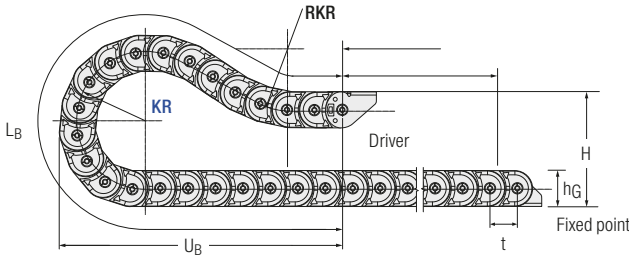

For more information on gliding arrangement please contact us.

Inner heights
39

Inner widths
74

Dynamics of gliding arrangement		t
v _{max} [m/s]	a _{max} [m/s ²]	[mm]
2.5	9	39

Installation dimensions gliding with RKR links

KR [mm]	H [mm]	n _{RKR}	L _B [mm]	U _B [mm]
46	142	0	222	149
58	150	2	405	196
70	150	3	551	257
95	150	4	770	341

Connection height H is standard. Please contact us if you require other connection heights H. We will be happy to advise you. Optionally, the Online Engineer is always available for the calculation.

The gliding cable carrier has to be routed in a channel. Our engineers will be happy to help with project planning – please contact us.

Calculating the cable carrier length

Cable carrier length L_k

$$L_k \approx \frac{L_s}{2} + L_B$$

Cable carrier length L_k rounded to pitch t

Key for abbreviations on page 20

Assembly instructions on kabelschlepp.de/assembly

Order key on page 19



TSUBAKI KABELSCHLEPP Technical Support

If you have any questions about determining gliding cable carriers or other technical details please contact our technical support service at technik@kabelschlepp.de. We will be happy to help you.

Stay variant 020 – closed frame

- Weight-optimized plastic frame with particularly high torsional rigidity.
- Opening options
outside/inside: Closed.

kabelschlepp.de/
tkk

Configure your cable carrier:
online-engineer.de



Stay arrangement on every chain link (VS)



B_i 74 mm

Technical support:
technik@kabelschlepp.de

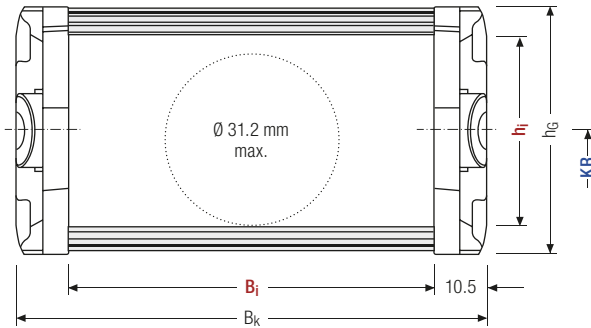

Calculating the cable carrier width

Outer width B_k

$$B_k = B_i + 21 \text{ mm}$$



The maximum cable diameter strongly depends on the bending radius and the desired cable type. Please contact us.



Pitch, inner height and chain link height

t [mm]	h _i [mm]	h _G [mm]
39	39	50

Inner heights



Bend radii

KR [mm]			
46	58	70	95

Inner widths



Inner/outer width and intrinsic cable carrier weight

B _i [mm]	B _k [mm]	q _k [kg/m]
74	95	1.56

Key for abbreviations on page 20

Order example



TKK39	·	020	·	74	·	70	·	1950
Type		Stay variant		B _i [mm]		KR [mm]		L _k [mm]

Assembly instructions on kabelschlepp.de/assembly



TOTALTRAX® complete systems

Benefit from the advantages of a TOTALTRAX® complete system. Complete delivery from a single source – with a guarantee certificate on request! Learn more at kabelschlepp.de/totaltrax



TRAXLINE® cables in motion

Hi-flex electric cables which were especially developed, optimized and tested for use in cable carriers can be found at traxline.de

Order key on page 19



Stay variant 040 – with inside opening crossbar

- Weight-optimized plastic frame with particularly high torsional rigidity.
- Swivable crossbars on one side in any position.
- **Opening options inside:** Swivable.

kabelschlepp.de/
tkk

Configure your cable carrier:
online-engineer.de



Stay arrangement on every chain link (VS)



B_i 74 mm

Technical support:
technik@kabelschlepp.de

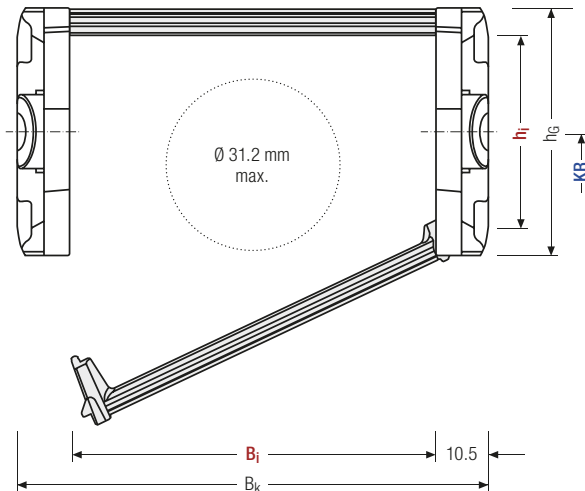

Calculating the cable carrier width

Outer width B_k

$$B_k = B_i + 21 \text{ mm}$$



The maximum cable diameter strongly depends on the bending radius and the desired cable type. Please contact us.

online-engineer.de
Cable Carrier Configurator



Pitch, inner height and chain link height

t [mm]	h _i [mm]	h _G [mm]
39	39	50

Inner heights

Bend radii

KR [mm]			
46	58	70	95

Inner widths

Inner/outer width and intrinsic cable carrier weight

B _i [mm]	B _k [mm]	q _k [kg/m]
74	95	1.56

Key for abbreviations on page 20

Order example



TKK39	·	040	·	74	·	70	·	1950
Type		Stay variant		B _i [mm]		KR [mm]		L _k [mm]

Assembly instructions on kabelschlepp.de/assembly

Order key on page 19



Divider systems

As standard, the divider system is assembled at each 2nd chain link.

As standard, dividers and the complete divider system (dividers with height separations) can be moved in the cross section (**version A**).

The dividers are easily attached to the stay for applications with transverse acceleration and for laterally recumbent applications.

The locking cams click into place in the locking grids in the crossbars (**version B**).

Movable divider

Version A (Standard)

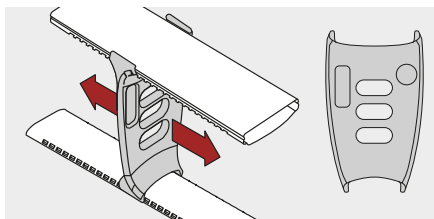

Fixable divider (2 mm grid)

Version B

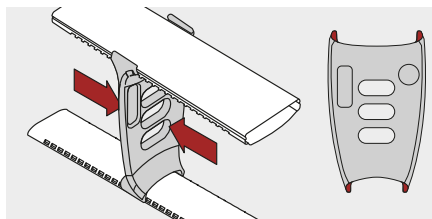

Configure your cable carrier:
online-engineer.de

Technical support:
technik@kabelschlepp.de

Divider system TSO without height separation

S _T [mm]	W _f [mm]	Version A			Version B			
		a _{TL} /a _{TR} min [mm]	a _x min [mm]	a _c min [mm]	a _{TL} /a _{TR} min [mm]	a _x min [mm]	a _c min [mm]	a _x Raster [mm]
3	10	5	10	7	5	10	7	2

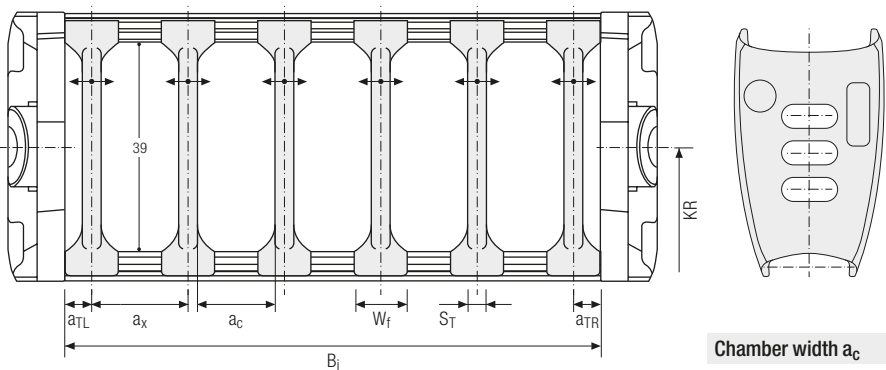

Chamber width a_c

$$a_c = a_x - S_T$$



For design 020, only version A can be used.



Information on the connection dimensions for the cable carrier can be found on page 18 f.

Divider system TS1 with continuous height separation

S _T [mm]	W _f [mm]	S _H [mm]	n _T min	Version A			Version B			
				a _T min [mm]	a _x min [mm]	a _c min [mm]	a _T min [mm]	a _x min [mm]	a _c min [mm]	a _x Raster [mm]
3	10	4	2	5	10	7	5	10	7	2

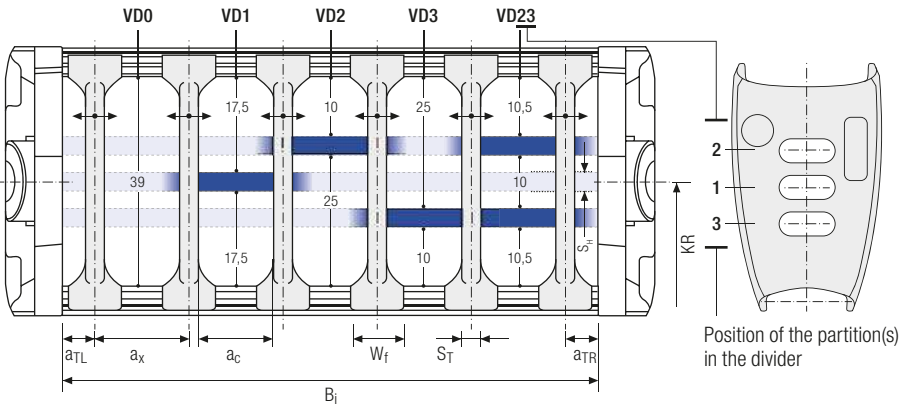

Inner heights



Inner widths



Key for abbreviations on page 20

Standard height separation with aluminum profile 11 × 4 mm. The dividers can be moved in the cross section.

Chamber width a_c

$$a_c = a_x - S_T$$



TOTALTRAX® complete systems

Benefit from the advantages of a TOTALTRAX® complete system. Complete delivery from a single source – with a guarantee certificate on request! Learn more at kabelschlepp.de/totaltrax



TRAXLINE® cables in motion

Hi-flex electric cables which were especially developed, optimized and tested for use in cable carriers can be found at traxline.de

More product information online



Assembly instructions etc.: Receive additional info via your smartphone or check online at kabelschlepp.de/support



Configure your custom cable carrier: online-engineer.de

Assembly instructions on kabelschlepp.de/assembly

Order key on page 19



One part end connectors – steel

The steel end connectors can be **connected from above or below**. The connection type can be changed by reconnecting the end connector.

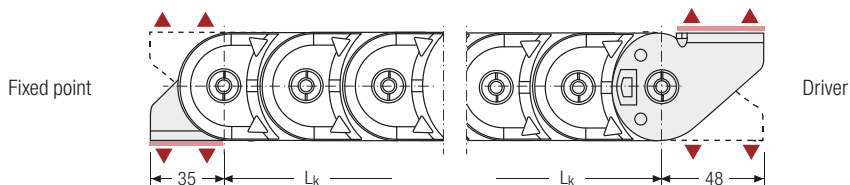

Configure your cable carrier:
online-engineer.de

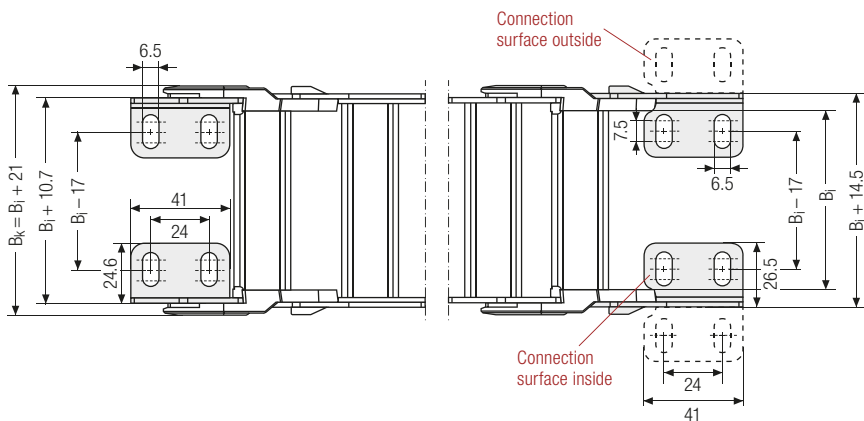

Technical support:
technik@kabelschlepp.de



TSUBAKI KABELSCHLEPP Technical Support

If you have any questions about determining gliding cable carriers or other technical details please contact our technical support service at technik@kabelschlepp.de. We will be happy to help you.

Connection variants

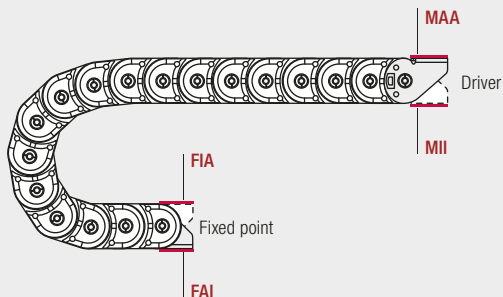

Connection point

- F – fixed point
- M – driver

Connection type

- A – threaded joint outside (standard)
- I – threaded joint inside

Connection surface

- I – connection surface inside
- A – connection surface outside

Order

Cable carrier

Type	Stay variant	B _i [mm]	KR [mm]	L _K [mm]
			46	
			58	
	020		70	
TKK39	040	74	95	

TKK39	020	74	70	1950
Type	Stay variant	B _i [mm]	KR [mm]	L _K [mm]

Inner heights



Inner widths



Divider system

Divider system	Version	n _T	Height separation (not for TSO)
TS0		min. 2	VD0
TS1	A

TS1	A	2	VD0
			⋮
			VD1
Divider system	Version	n _T	Height separation

Key for abbreviations on page 20

Please state the designation of the divider system (TS0, TS1), version and number of dividers per cross section [n_T].

Connection variant

End connector	Connection point	Connection type	Connection surface
End connector	F	A	I
End connector	M	I	A

End connector	F	I	A
End connector	M	A	I

Please state the desired connection variant as well as the desired strain relief type for the fixed point and for the driver.

Assembly instructions on kabelschlepp.de/assembly

Order key on page 19









































General abbreviations

a_c	= nominal width inner chamber	l_A	= length of end connector
a_{max}	= max. travel acceleration	L_B	= length of carrier in bend
a_{TL}	= distance lateral tabs inside to center of first divider	L_D	= length of permitted sag
a_{TR}	= distance lateral tabs inside to center of last divider	L_f	= unsupported length
a_x	= divider center to center distance	L_{ES}	= length of energy conduit
b_1	= inner width of guide channel	L_k	= cable carrier length without connection
b_A	= distance between connection boreholes	L_S	= travel length
B_{EF}	= overall width of cable carrier incl. attachments	L_v	= fixed point offset
B_i	= inner width	n_p	= number of hole stay inserts
B_k	= outer width	n_{RKR}	= number of RKR links
B_{KA}	= outer width of guide channel	n_T	= number of dividers
B_p	= width of hole stay inserts	n_Z	= number of comb teeth for strain relief
B_{St}	= stay width	q_k	= intrinsic cable carrier weight
c	= distance between hole stay bores	q_z	= additional load
d	= diameter	RKR	= reverse bending radius
D	= bore diameter	s	= sheet metal thickness
d_R	= pipe diameter	S_H	= thickness of height separation
H	= connection height	S_T	= thickness of divider
h_G	= chain link height	t	= pitch
h_G'	= chain link height incl. glide shoe	U_B	= loop overhang
h_i	= inner height	VD	= position of continuous height separations in divider
H_i	= inner height of frame stay assembly	VR	= position of partial height separations in divider
h_{KA}	= outer height of guide channel	v_{max}	= max. travel speed
HS	= half-stayed	VS	= fully-stayed
H_z	= installation height	W_f	= base width of divider
KR	= bending radius	z	= pretension
l_1	= connection length		
l_{2-5}	= connection dimensions		

Definitions

Driver view = view into the driver connection

Pictographs

	inner height		stay arrangement on every 2 nd chain link		clean room suitable
	inner width		stay arrangement on every chain link		quiet running/low noise
	inner width (B _i) in x mm increments		cannot be opened		sold by the meter
	pitch		opens outward		ESD material
	bending radius		opens inward		suitable for explosive atmospheres
	long travel length		opens inward/outward		heat-resistant
	travel length unsupported		covered cable carrier		cold-resistant
	travel length gliding		sliding dividers		resistant to hot chips
	high additional load		fixable dividers		flame-resistant V0 (UL94)
	high travel acceleration		fixable dividers in x mm grid		flame-resistant V2 (UL94)
	high travel velocity		height separation possible		order code
			height separation in 1 mm increments		important information
			hole stay available		
			guide channel required		
			strain relief		

Inner heights

39

Inner widths

74

Key for abbreviations on page 20

Assembly instructions on kabelschlepp.de/assembly